

CAP9010FR-B | VL

Brake tester



Capelec[®]
Ergonomics Efficiency Simplicity



Photo non contractuelle

Built-in brake tester rollers

- Complete integrated solution
- PC box | WIN OS
- 22" touch screen
- Compact, ergonomic totem
- S9010 procedure software
- CAP1000 remote control
- Light vehicles: cars, vans, 4x4s
- Galvanized steel frame
- 4x4 or reverse rotation function
- Interconnectable or independent
- High-adhesion epoxy-coated aluminum rollers
- Positioning aid
- Load cells
- Soft start and roller lock (optional)

Made in France



SPECIFICATIONS :

Dimensions: 232 x 69 x 32 cm
Max. axle load: 4 t Motor: 4 kW
(ABM Germany) Test speed: 5 km/h
Measuring range: 0-750 daN
Braking clearance: 80-220 cm

OPTIONS :

27" touch screen
Cover plates Foux rollers
Mobile pedestal
Lane widener
Remote display

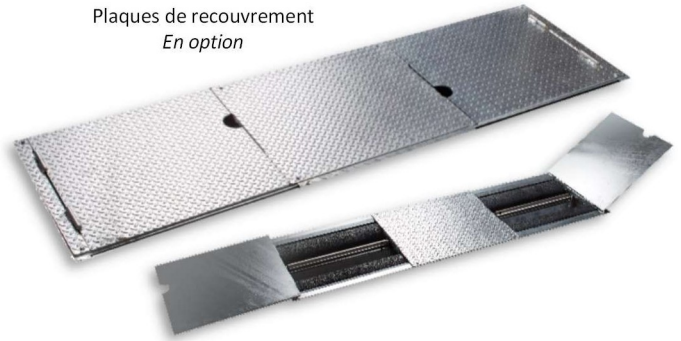
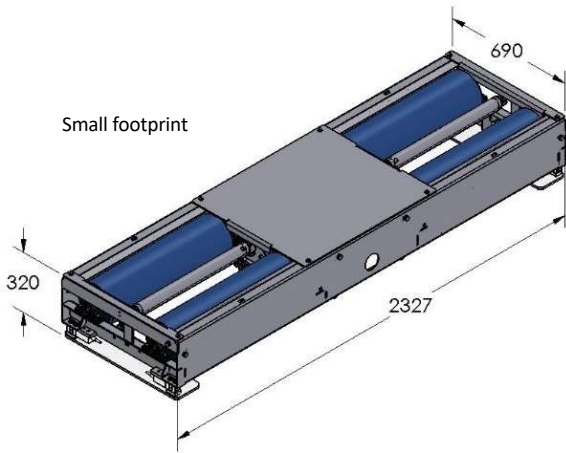
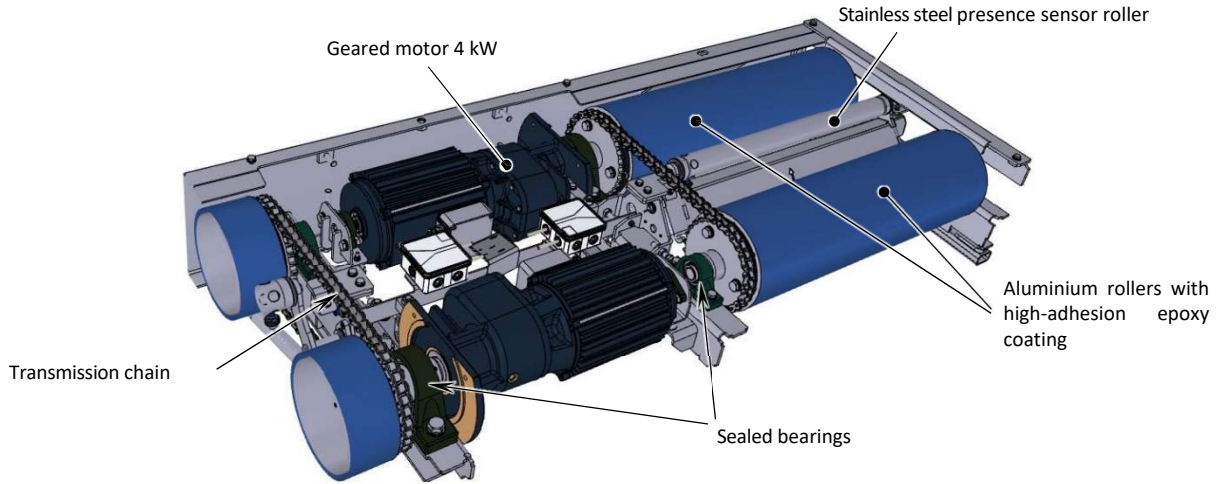

Touch screen
S9010 software



Remote control



Aluminium rollers with
high-adhesion epoxy
coating



Suspension
control
(optional)



Crazy rollers
for 4x4
(optional)

More information

www.capelec.com

1130 rue des Marels | Parc Eureka | 34000 Montpellier | France | Tel (33)4 67 156 156 | Fax (33)4 67 224 224